

# INVERTER

**F700**

# INSTALLATION GUIDELINE

## FR-F 740-00023 to 02160-EC

Thank you for choosing this Mitsubishi Inverter.

Please read through this Instruction Manual and the enclosed CD ROM to operate this inverter correctly

- The enclosed CD ROM contains the Installation Guideline in additional languages.
- Die CD-ROM enthält die deutsche Installationsbeschreibung.
- Il CD-ROM incluso contiene la guida di riferimento dell'installazione in lingua italiana.
- Le CD-ROM ci-joint contient cette documentation en français.
- El CD-ROM incluido contiene la pauta de la instalación en lengua española.
- Приложенный CD-ROM содержит инструкцию по инсталляции на дополнительных языках.

Do not use this product until you have a full knowledge of the equipment, the safety information and the instructions.

Please forward this manual and the CD ROM to the end user.

### CONTENTS

<b>[1]</b>	<b>INSTALLATION OF THE INVERTER AND INSTRUCTIONS</b> .....	<b>1</b>
<b>[2]</b>	<b>OUTLINE DRAWING</b> .....	<b>3</b>
<b>[3]</b>	<b>WIRING</b> .....	<b>4</b>
<b>[4]</b>	<b>PRECAUTIONS FOR USE OF THE INVERTER</b> .....	<b>8</b>
<b>[5]</b>	<b>PARAMETER LIST</b> .....	<b>9</b>
<b>[6]</b>	<b>TROUBLESHOOTING</b> .....	<b>15</b>

*F700*

Print Date	Manual Number	Revision
August 2004	158537	First edition



**For Maximum Safety**

- Mitsubishi transistorized inverters are not designed or manufactured to be used in equipment or systems in situations that can affect or endanger human life.
- When considering this product for operation in special applications such as machinery or systems used in passenger transportation, medical, aerospace, atomic power, electric power, or submarine repeating applications, please contact your nearest Mitsubishi sales representative.
- Although this product was manufactured under conditions of strict quality control, you are strongly advised to install safety devices to prevent serious accidents when it is used in facilities where breakdowns of the product are likely to cause a serious accident.
- Please do not use this product for loads other than three-phase induction motors.

### This section is specifically about safety matters

Do not attempt to install, operate, maintain or inspect the inverter until you have read through this Installation Guideline and appended documents carefully and can use the equipment correctly. Do not use the inverter until you have a full knowledge of the equipment, safety information and instructions. In this Installation Guideline, the safety instruction levels are classified into "WARNING" and "CAUTION".



#### WARNING

Assumes that incorrect handling may cause hazardous conditions, resulting in death or severe injury.



#### CAUTION

Assumes that incorrect handling may cause hazardous conditions, resulting in medium or slight injury, or may cause physical damage only.

Note that even the **CAUTION** level may lead to a serious consequence according to conditions. Please follow strictly the instructions of both levels because they are important to personnel safety.

### Electric Shock Prevention

#### WARNING

- While power is on or when the inverter is running, do not open the front cover. Otherwise you may get an electric shock.
- Do not run the inverter with the front cover removed. Otherwise, you may access the exposed high-voltage terminals or the charging part of the circuitry and get an electric shock.
- Even if power is off, do not remove the front cover except for wiring or periodic inspection. You may access the charged inverter circuits and get an electric shock.
- Before starting wiring or inspection, check to make sure that the operation panel indicator is off, wait for at least 10 minutes after the power supply has been switched off, and check that there are no residual voltage using a tester or the like. The capacitor is charged with high voltage for some time after power off and it is dangerous.
- This inverter must be earthed. Earthing must conform to the requirements of national and local safety regulations and electrical codes. (JIS, NEC section 250, IEC 536 class 1 and other applicable standards)
- Any person who is involved in the wiring or inspection of this equipment should be fully competent to do the work.
- Always install the inverter before wiring. Otherwise, you may get an electric shock or be injured.
- Perform setting dial and key operations with dry hands to prevent an electric shock. Otherwise you may get an electric shock.
- Do not subject the cables to scratches, excessive stress, heavy loads or pinching. Otherwise you may get an electric shock.
- Do not replace the cooling fan while power is on. It is dangerous to replace the cooling fan while power is on.
- Do not touch the printed circuit board with wet hands. You may get an electric shock.

### Fire Prevention

#### CAUTION

- Mount the inverter to incombustible material. Mounting it to or near combustible material can cause a fire.
- If the inverter has become faulty, switch off the inverter power.  
A continuous flow of large current could cause a fire.
- Do not connect a resistor directly to the DC terminals P, N. This could cause a fire and destroy the inverter. The surface temperature of braking resistors can far exceed 100°C for brief periods. Make sure that there is adequate protection against accidental contact and a safe distance is maintained to other units and system parts.

### Injury Prevention

#### CAUTION

- Apply only the voltage specified in the instruction manual to each terminal. Otherwise, burst, damage, etc. may occur.
- Ensure that the cables are connected to the correct terminals. Otherwise, burst, damage, etc. may occur.
- Always make sure that polarity is correct to prevent damage, etc. Otherwise, burst, damage, etc. may occur.
- While power is on or for some time after power-off, do not touch the inverter as it is hot and you may get burnt.

### Additional Instructions

Also note the following points to prevent an accidental failure, injury, electric shock, etc.

### Transportation and installation

#### CAUTION

- When carrying products, use correct lifting gear to prevent injury.
- Do not stack the inverter boxes higher than the number recommended.
- Ensure that installation position and material can withstand the weight of the inverter. Install according to the information in the instruction manual.
- Do not install or operate the inverter if it is damaged or has parts missing. This can result in breakdowns.
- When carrying the inverter, do not hold it by the front cover or setting dial; it may fall off or fail.
- Do not stand or rest heavy objects on the product.
- Check the inverter mounting orientation is correct.
- Prevent other conductive bodies such as screws and metal fragments or other flammable substance such as oil from entering the inverter.
- As the inverter is a precision instrument, do not drop or subject it to impact.
- Use the inverter under the following environmental conditions. Otherwise, the inverter may be damaged.

Environment	Ambient temperature	-10°C to +40/+50°C (non-freezing) The maximum temperature depends on the setting of the Pr. 570.
	Ambient humidity	90% RH or less (non-condensing)
	Storage temperature	-20°C to +65°C *
	Atmosphere	Indoors (free from corrosive gas, flammable gas, oil mist, dust and dirt)
	Altitude, vibration	Maximum 1000m above sea level for standard operation. After that derate by 3% for every extra 500m up to 2500m (92%) 5.9m/s <sup>2</sup> or less (conforming to JIS C 0040)

\*Temperature applicable for a short time, e.g. in transit.

## Wiring

### ⚠ CAUTION

- Do not install assemblies or components (e. g. power factor correction capacitors) on the inverter output side, which are not approved from Mitsubishi.
- The direction of rotation of the motor corresponds to the direction of rotation commands (STF/STR) only if the phase sequence (U, V, W) is maintained.

## Test operation and adjustment

### ⚠ CAUTION

- Before starting operation, confirm and adjust the parameters. A failure to do so may cause some machines to make unexpected motions.

## Operation

### ⚠ WARNING

- When you have chosen the retry function, stay away from the equipment as it will restart suddenly after an alarm stop.
- The  key is valid only when the appropriate function setting has been made. Prepare an emergency stop switch separately.
- Make sure that the start signal is off before resetting the inverter alarm. A failure to do so may restart the motor suddenly.
- The load used should be a three-phase induction motor only. Connection of any other electrical equipment to the inverter output may damage the inverter as well as the equipment.
- Do not modify the equipment.
- Do not perform parts removal which is not instructed in this manual. Doing so may lead to fault or damage of the inverter.

### ⚠ CAUTION

- The electronic thermal relay function does not guarantee protection of the motor from overheating.
- Do not use a magnetic contactor on the inverter input for frequent starting/stopping of the inverter.
- Use a noise filter to reduce the effect of electromagnetic interference. Otherwise nearby electronic equipment may be affected.
- Take appropriate measures regarding harmonics. Otherwise this can endanger compensation systems or overload generators.
- Use a motor designed for inverter operation. (The stress for motor windings is bigger than in line power supply).
- When parameter clear or all clear is performed, set again the required parameters before starting operations. Each parameter returns to the initial value.
- The inverter can be easily set for high-speed operation. Before changing its setting, fully examine the performances of the motor and machine.
- The DC braking function of the frequency inverter is not designed to continuously hold a load. Use an electro-mechanical holding brake on the motor for this purpose.
- Before running an inverter which had been stored for a long period, always perform inspection and test operation.
- For prevention of damage due to static electricity, touch nearby metal before touching this product to eliminate static electricity from your body.

## Emergency stop

### ⚠ CAUTION

- Provide a safety backup such as an emergency brake which will prevent the machine and equipment from hazardous conditions if the inverter fails.
- When the breaker on the inverter primary side trips, check for the wiring fault (short circuit), damage to internal parts of the inverter, etc. Identify the cause of the trip, then remove the cause and power on the breaker.
- When the protective function is activated (i. e. the frequency inverter switches off with an error message), take the corresponding corrective action as described in the inverter manual, then reset the inverter, and resume operation.

## Maintenance, inspection and parts replacement

### ⚠ CAUTION

- Do not carry out a megger (insulation resistance) test on the control circuit of the inverter.

## Disposing of the inverter

### ⚠ CAUTION

- Treat as industrial waste.

## General instructions

Many of the diagrams and drawings in instruction manuals show the inverter without a cover, or partially open. Never run the inverter in this status. Always replace the cover and follow instruction manuals when operating the inverter.



## 1.3 General Precaution

The bus capacitor discharge time is 10 minutes. Before starting wiring or inspection, switch power off, wait for more than 10 minutes, and check for residual voltage between terminal P/+ and N/- with a meter etc., to avoid a hazard of electrical shock.

## 1.4 Environment

Before installation, check that the environment meets following specifications.

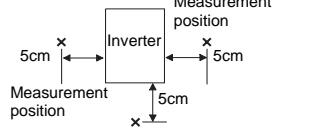
<b>Ambient temperature</b>	-10°C to +50°C (non-freezing) for selected overload capability 150% (Pr. 570 = 0) -10°C to +40°C (non-freezing) for selected overload capability 120% (Pr. 570 = 1)	
<b>Ambient humidity</b>	90% RH or less (non-condensing)	
<b>Storage temperature</b>	-20°C to +65°C	
<b>Ambience</b>	Indoors (No corrosive and flammable gases, oil mist, dust and dirt)	
<b>Altitude, vibration</b>	Below 1000m, 5.9m/s <sup>2</sup> or less	

### CAUTION

- Install the inverter on a strong surface securely and vertically with bolts.
- Leave enough clearances and take cooling measures.
- Avoid places where the inverter is subjected to direct sunlight, high temperature and high humidity.
- Install the inverter on a non-combustible surface.

## 2 OUTLINE DRAWING

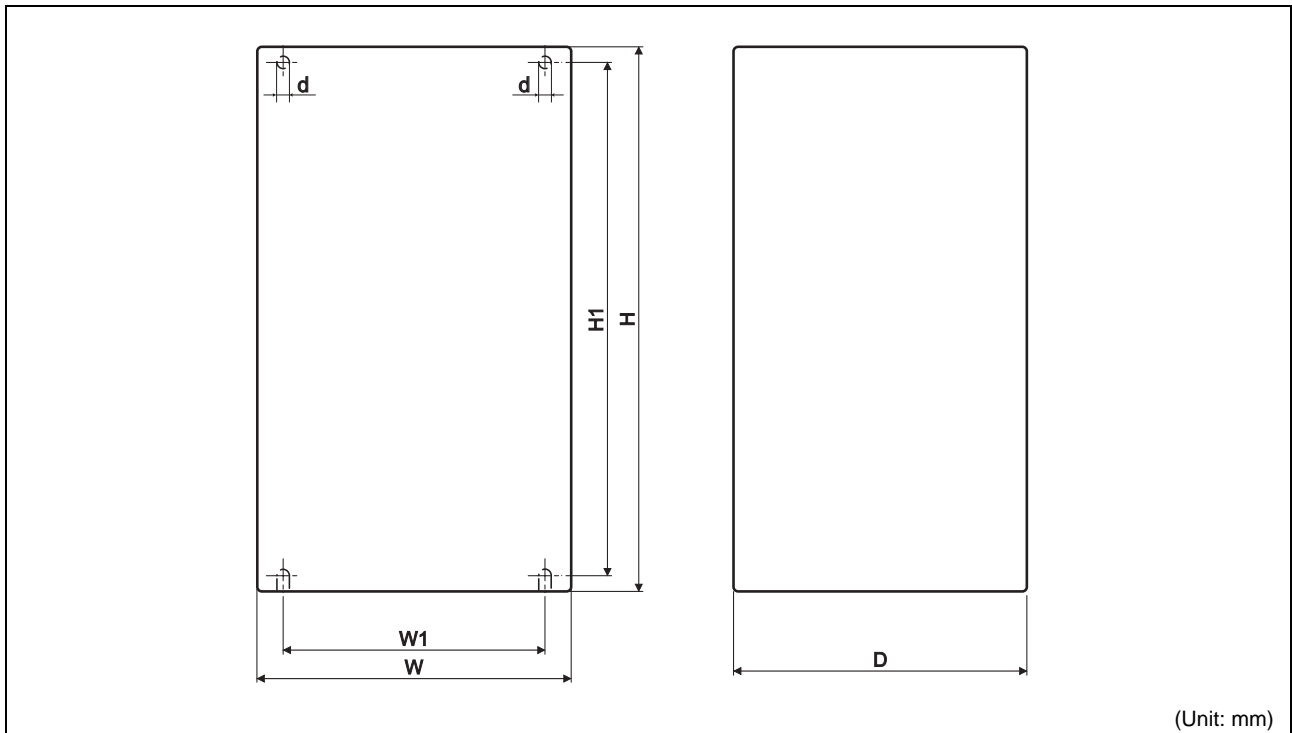

	W	W1	H	H1	D	d
FR-F 740-00023-EC	150	125	260	245	140	6
FR-F 740-00038-EC						
FR-F 740-00052-EC						
FR-F 740-00083-EC						
FR-F 740-00126-EC	220	195	260	245	170	6
FR-F 740-00170-EC						
FR-F 740-00250-EC	220	195	300	285	190	6
FR-F 740-00310-EC						
FR-F 740-00380-EC	250	230	400	380	190	10
FR-F 740-00470-EC						
FR-F 740-00620-EC	325	270	550	530	195	10
FR-F 740-00770-EC						
FR-F 740-00930-EC	435	380	550	525	250	12
FR-F 740-01160-EC						
FR-F 740-01800-EC						
FR-F 740-02160-EC	465	400	620	595	300	12

# 3 WIRING

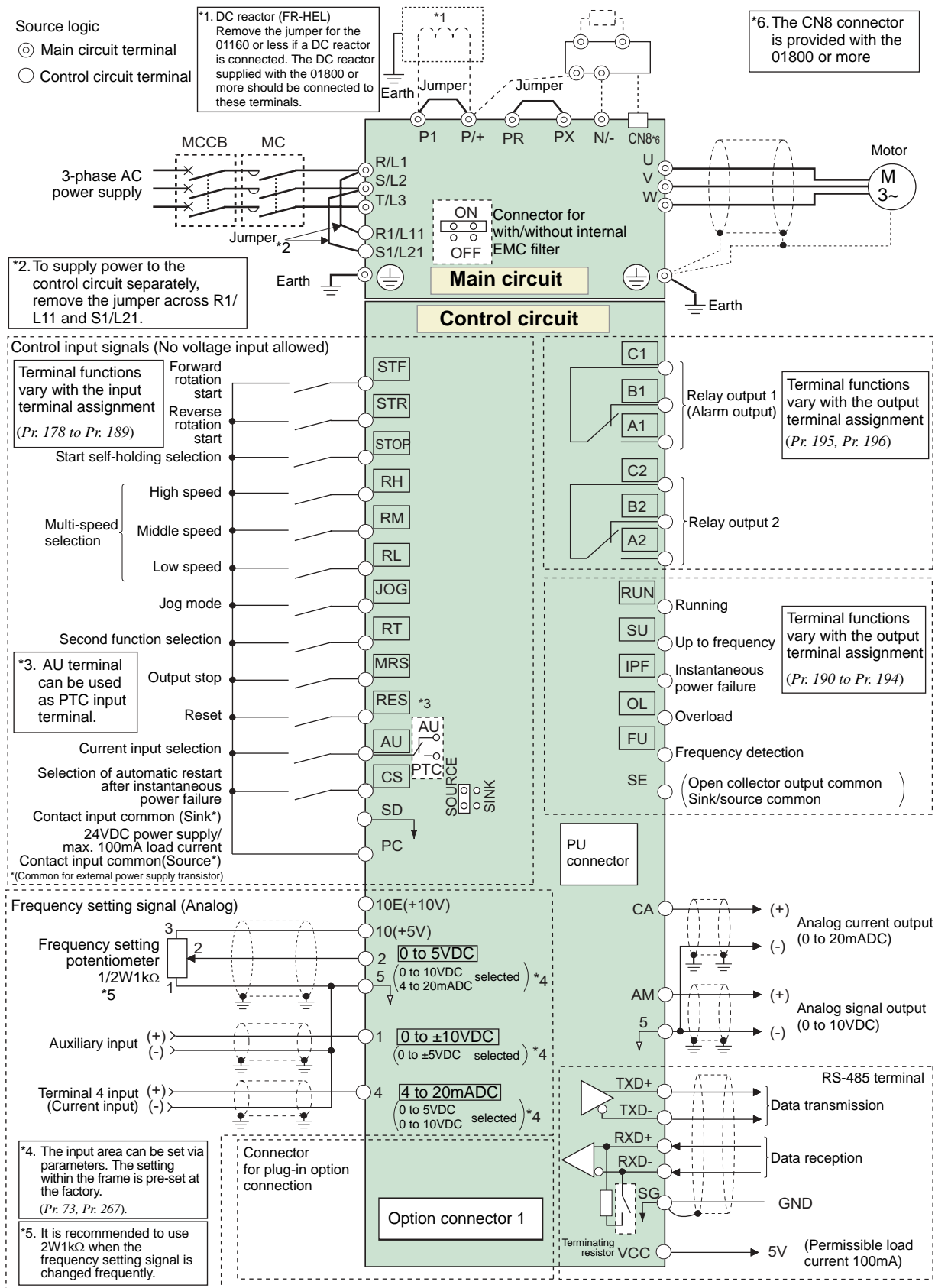

## CAUTION

- To prevent a malfunction due to noise, keep the signal cables more than 10cm away from the power cables.
- After wiring, wire offcuts must not be left in the inverter. Wire offcuts can cause an alarm, failure or malfunction. Always keep the inverter clean. When drilling mounting holes in a control box etc., take care not to allow chips and other foreign matter to enter the inverter.

### 3.1 Main circuit terminal

#### 3.1.1 Terminal layout and wiring

FR-F 740-00023, 00038, 00052, 00083, 00126-EC

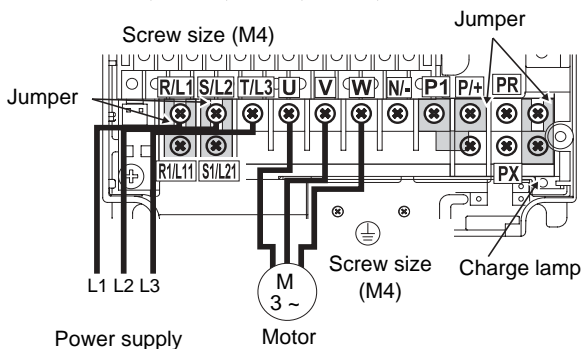

FR-F 740-00170, 00250-EC

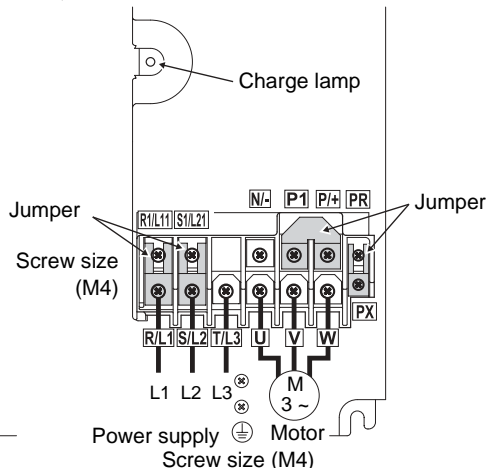

FR-F 740-00310, 00380-EC

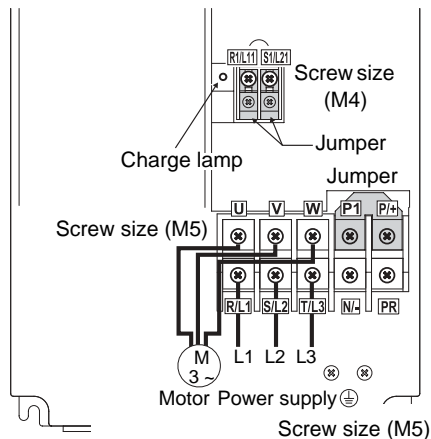

FR-F 740-00470, 00620-EC

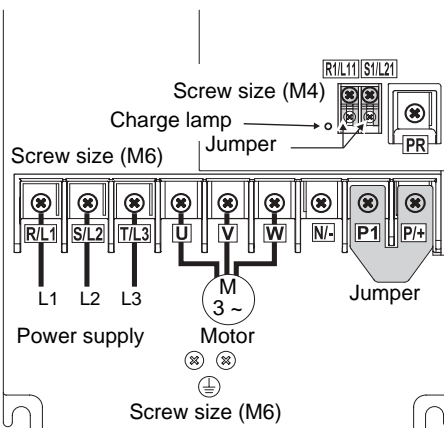

FR-F 740-00700 to 01060-EC

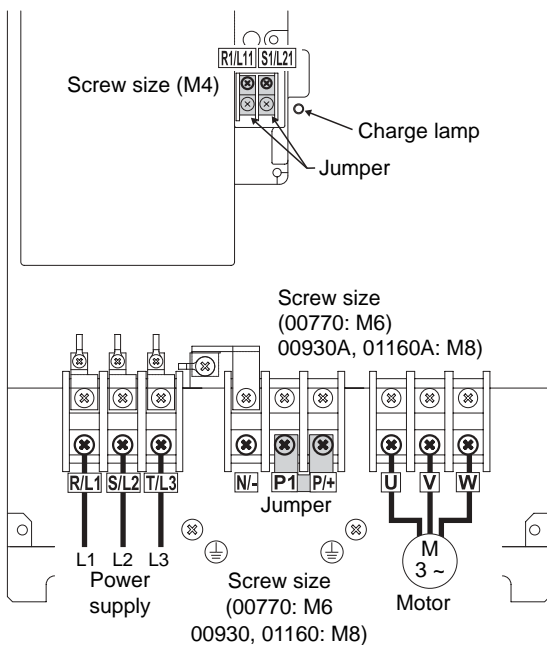

FR-F 740-01800 to 02160-EC

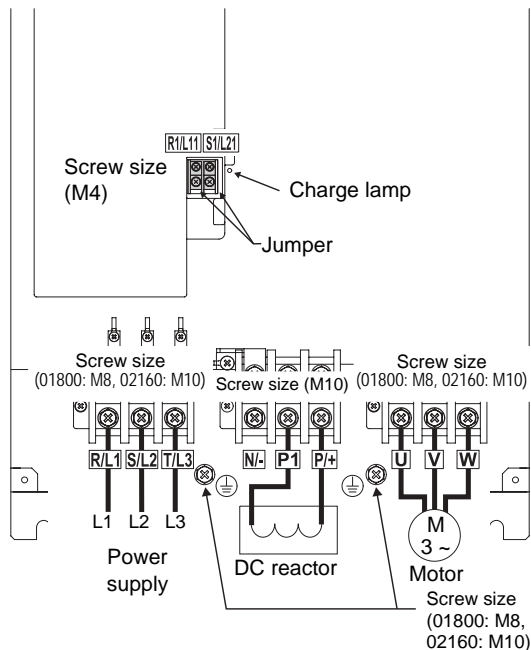

#### CAUTION

- The power supply cables must be connected to R/L1, S/L2, T/L3. Never connect the power cable to the U, V, W, of the inverter. Doing so will damaged the inverter. (Phase sequence needs not to be matched.)
- Connect the motor to U, V, W. At this time turning on the forward rotation switch (signal) rotates the motor in the counterclockwise direction when viewed from the motor shaft.



## 3.2 Wiring fundamentals

### 3.2.1 Cable size

Select the recommended cable size to ensure that a voltage drop will be 2% max.

If the wiring distance is long between the inverter and motor, a main circuit cable voltage drop will cause the motor torque to decrease especially at the output of a low frequency.

The following table indicates a selection example for the wiring length of 20m.

**400V class (when input power supply is 440V based on the rated current for 110% overload for 1 minute)**

Applicable Inverter Type	Terminal Screw Size *4	Tightening Torque [N·m]	Crimping Terminal	
			R/L1, S/L2, T/L3	U, V, W
FR-F 740-00023 to 00083-EC	M4	1.5	2-4	2-4
FR-F 740-00126-EC	M4	1.5	2-4	2-4
FR-F 740-00170-EC	M4	1.5	5.5-4	5.5-4
FR-F 740-00250-EC	M4	1.5	5.5-4	5.5-4
FR-F 740-00310-EC	M5	2.5	8-5	8-5
FR-F 740-00380-EC	M5	2.5	14-5	8-5
FR-F 740-00470-EC	M6	4.4	22-6	14-6
FR-F 740-00620-EC	M6	4.4	22-6	22-6
FR-F 740-00770-EC	M6	4.4	22-6	22-6
FR-F 740-00930-EC	M8	7.8	38-8	38-8
FR-F 740-01160-EC	M8	7.8	60-8	60-8
FR-F 740-01800-EC	M8	7.8	60-10	60-10
FR-F 740-02160-EC	M10	14.7	100-10	100-10

Applicable Inverter Type	Cable Sizes								
	HIV, etc. [mm <sup>2</sup> ] *1			AWG *2			PVC, etc. [mm <sup>2</sup> ] *3		
	R/L1, S/L2, T/L3	U, V, W	Earth Cable Gauge	R/L1, S/L2, T/L3	U, V, W	R/L1, S/L2, T/L3	U, V, W	Earth Cable Gauge	
FR-F 740-00023 to 00083-EC	2	2	2	14	14	2.5	2.5	2.5	
FR-F 740-00126-EC	2	2	3.5	12	14	2.5	2.5	4	
FR-F 740-00170-EC	3.5	3.5	3.5	12	12	4	4	4	
FR-F 740-00250-EC	5.5	5.5	8	10	10	6	6	10	
FR-F 740-00310-EC	8	8	8	8	8	10	10	10	
FR-F 740-00380-EC	14	8	14	6	8	16	10	16	
FR-F 740-00470-EC	22	14	14	4	6	25	16	16	
FR-F 740-00620-EC	22	22	14	4	4	25	25	16	
FR-F 740-00770-EC	22	22	14	4	4	25	25	16	
FR-F 740-00930-EC	38	38	22	1	2	50	50	25	
FR-F 740-01160-EC	60	60	22	1/0	1/0	50	50	25	
FR-F 740-01800-EC	60	60	38	1/0	1/0	50	50	25	
FR-F 740-02160-EC	100	100	38	3/0	3/0	70	70	35	

\*1 For the 01160 or less, the recommended cable size is that of the HIV cable (600V class 2 vinyl-insulated cable) with continuous maximum permissible temperature of 75°C. Assumes that the ambient temperature is 50°C or less and the wiring distance is 20m or less.

For the 01800 or more, the recommended cable size is that of LMFC (heat resistant flexible cross-linked polyethylene insulated cable) with continuous maximum permissible temperature of 105°C. Assumes that the ambient temperature is 50°C or less and wiring is performed in an enclosure.

\*2 For the 00930 or less, the recommended cable size is that of the THHW cable with continuous maximum permissible temperature of 75°C. Assumes that the ambient temperature is 40°C or less and the wiring distance is 20m or less.

For the 01160 or more, the recommended cable size is that of THHN cable with continuous maximum permissible temperature of 90°C. Assumes that the ambient temperature is 40°C or less and wiring is performed in an enclosure.

\*3 For the 00930 or less, the recommended cable size is that of the PVC cable with continuous maximum permissible temperature of 70°C. Assumes that the ambient temperature is 40°C or less and the wiring distance is 20m or less.

For the 01160 or more, the recommended cable size is that of XLPE cable with continuous maximum permissible temperature of 90°C. Assumes that the ambient temperature is 40°C or less and wiring is performed in an enclosure.

\*4 The terminal screw size indicates the terminal size for R/L1, S/L2, T/L3, U, V, W, and a screw for earthing.

The line voltage drop can be calculated by the following expression:

$$\text{line voltage drop [V]} = \frac{\sqrt{3} \times \text{wire resistance } [\Omega] \times \text{wiring distance [m]} \times \text{current [A]}}{1000}$$

Use a larger diameter cable when the wiring distance is long or when it is desired to decrease the voltage drop (torque reduction) in the low speed range.

#### CAUTION

- Tighten the terminal screw to the specified torque.  
A screw that has been tighten too loosely can cause a short circuit or malfunction.  
A screw that has been tighten too tightly can cause a short circuit or malfunction due to the unit breakage.
- Use crimping terminals with insulation sleeve to wire the power supply and motor.

### 3.2.2 Total wiring length

The wiring length should be 500m maximum.

(The overall wiring length for connection of multiple motors should be within the value in the table below.)

Pr. 72 PWM frequency selection setting (carrier frequency)	00023	00038	00052 or more
2 (2kHz) or less	300m	500m	500m
3 (3kHz), 4 (4kHz)	200m	300m	500m
5 (5kHz) to 9 (9kHz)	100m		
10 (10kHz) or more	50m		

Note that the motor windings in three-phase AC motors are subject to far more stress when operated via frequency inverters than with mains operation. The motor must have been approved by the manufacturer for operation on a frequency inverter.

#### CAUTION

- Especially for long-distance wiring (particularly when employing shielded motor cables), the inverter may be affected by a charging current caused by the stray capacitances of the wiring, leading to a malfunction of the overcurrent protective function or fast response current limit function or a malfunction or fault of the equipment connected on the inverter output side. When the fast-response current limit function malfunctions, make the function invalid. (For Pr.156 Stall prevention operation selection, refer to the Instruction Manual (applied).)
- For details of Pr. 72 PWM frequency selection, refer to the Instruction Manual (applied).

### 3.2.3 Cable size of the control circuit power supply (terminal R1/L11, S1/L21)

- Terminal Screw Size: M4
- Cable size: 0.75mm<sup>2</sup> to 2mm<sup>2</sup>
- Tightening torque: 1.5N·m

## 3.3 Control circuit terminals

### 3.3.1 Terminal layout

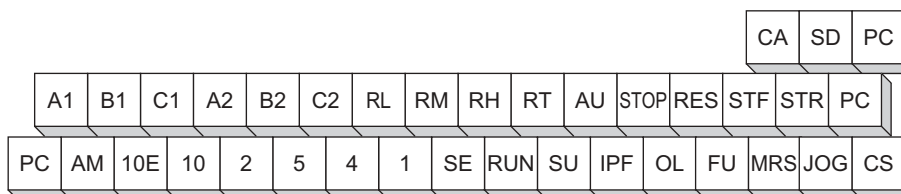

### 3.3.2 Instructions for wiring of the control circuit terminal

- Terminals 5, PC and SE are common to the I/O signals and isolated from each other. Do not earth.
- Use shielded or twisted cables for connection to the control circuit terminals and run them away from the main and power circuits (including the 230V relay sequence circuit).
- Use two or more parallel micro-signal contacts or twin contacts to prevent a contact faults when using contact inputs since the control circuit input signals are micro-currents.

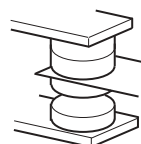

Micro signal contacts

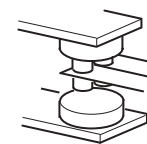

Twin contacts

- Do not apply a voltage to the contact input terminals (e.g. STF) of the control circuit.
- Always apply a voltage to the alarm output terminals (A, B, C) via a relay coil, lamp, etc.
- It is recommended to use the cables of 0.75mm<sup>2</sup> gauge for connection to the control circuit terminals. If the cable gauge used is 1.25mm<sup>2</sup> or more, the front cover may be lifted when there are many cables running or the cables are run improperly, resulting in an operation panel contact fault.
- The wiring length should be 30m maximum.
- The level of the control signals can be switched over by plugging the jumper over between positive (SOURCE) and negative (SINK) logic. The jumper is located at the upper front side of the control terminal connector.

---

---

## 4 PRECAUTIONS FOR USE OF THE INVERTER

---

---

The FR-F700 series is a highly reliable product, but incorrect peripheral circuit making or operation/handling method may shorten the product life or damage the product.

Before starting operation, always recheck the following items.

- Use crimping terminals with insulation sleeve to wire the power supply and motor.
- Application of power to the output terminals (U, V, W) of the inverter will damage the inverter. Never perform such wiring.
- After wiring, wire offcuts must not be left in the inverter.  
Wire offcuts can cause an alarm, failure or malfunction. Always keep the inverter clean. When drilling mounting holes in a control box etc., take care not to allow chips and other foreign matter to enter the inverter.
- Use cables of the size to make a voltage drop 2% maximum.  
If the wiring distance is long between the inverter and motor, a main circuit cable voltage drop will cause the motor torque to decrease especially at the output of a low frequency.  
Refer to *page 6* for the recommended cable size.
- The overall wiring length should be 500m maximum.  
Especially for long distance wiring, the fast-response current limit function may be reduced or the equipment connected to the inverter output side may malfunction or become faulty under the influence of a charging current due to the stray capacity of the wiring. Therefore, note the overall wiring length. (Refer to *page 7*)
- Electromagnetic wave interference  
The input/output (main circuit) of the inverter includes harmonic components, which may interfere with the communication devices (such as AM radios) used near the inverter. An EMC filter can minimize noise interference.
- Do not install a power factor correction capacitor, varistor or arrester on the inverter output side. This will cause the inverter to trip or the capacitor, varistor, or arrester to be damaged. If any of the above devices is installed, immediately remove it.
- Before starting wiring or other work after the inverter is operated, wait for at least 10 minutes after the power supply has been switched off, and check that there are no residual voltage using a tester or the like. The capacitor is charged with high voltage for some time after power off and it is dangerous.
- A short circuit or earth fault on the inverter output side may damage the inverter modules.
  - Fully check the insulation resistance of the circuit prior to inverter operation since repeated short circuits caused by peripheral circuit inadequacy or an earth fault caused by wiring inadequacy or reduced motor insulation resistance may damage the inverter modules.
  - Fully check the to-earth insulation and inter-phase insulation of the inverter output side before power-on.  
Especially for an old motor or use in hostile atmosphere, securely check the motor insulation resistance etc.
- Do not use the inverter input side magnetic contactor to start/stop the inverter.  
Always use the start signal (ON/OFF of STF and STR signals) to start/stop the inverter.
- Do not apply a voltage higher than the permissible voltage to the inverter I/O signal circuits.  
Contact to the inverter I/O signal circuits or opposite polarity may damage the I/O devices. Especially check the wiring to prevent the speed setting potentiometer from being connected incorrectly to short terminals 10E (10, respectively) -5.
- Provide electrical and mechanical interlocks for MC1 and MC2 which are used for commercial power supply-inverter switch-over.  
When the wiring is incorrect or if there is a commercial power supply-inverter switch-over circuit as shown below, the inverter will be damaged by leakage current from the power supply due to arcs generated at the time of switch-over or chattering caused by a sequence error.

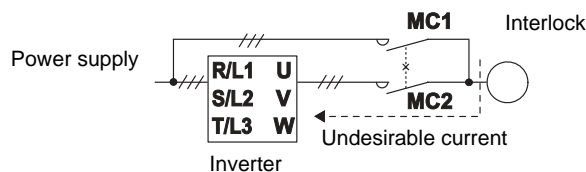

- If the machine must not be restarted when power is restored after a power failure, provide a magnetic contactor in the inverter's input side and also make up a sequence which will not switch on the start signal.  
If the start signal (start switch) remains on after a power failure, the inverter will automatically restart as soon as the power is restored.
- Instructions for overload operation  
When performing operation of frequent start/stop of the inverter, increase/decrease in the temperature of the transistor element of the inverter may repeat due to a continuous flow of large current, shortening the life from thermal fatigue. Since thermal fatigue is related to the amount of current, the life can be increased by reducing bound current, starting current, etc. Decreasing current may increase the life. However, decreasing current will result in insufficient torque and the inverter may not start. Therefore, increase the inverter capacity to have enough allowance for current.
- Make sure that the specifications and rating match the system requirements.

# 5 PARAMETER

## 5.1 Parameter list

In the initial setting, only the simple mode parameters are displayed.

Set Pr. 160 User group read selection as required.

Parameter	Name	Initial Value	Setting Range	Remarks
160	User group read selection	9999	9999	Only the simple mode parameters can be displayed.
			0	Simple mode and extended mode parameters can be displayed.
			1	Only parameters registered in the user group can be displayed.

### Remarks

- The parameters marked © are the simple mode parameters.
- The parameters marked with  in the table allow its setting to be changed during operation even if "0" (initial value) is set in Pr. 77 Parameter write selection.
- Parameters for the option are displayed only when the option unit is installed.

Parameters	Name	Setting Range	Initial Value	Parameters	Name	Setting Range	Initial Value
© 0	Torque boost	0 to 30%	6/4/3/2/1.5/ 1% *2	17	MRS input selection	0, 2	0
© 1	Maximum frequency	0 to 120Hz	120/60Hz *1	18	High speed maximum frequency	120 to 400Hz	120/60Hz *1
© 2	Minimum frequency	0 to 120Hz	0Hz	19	Base frequency voltage	0 to 1000V, 8888, 9999	8888
© 3	Base frequency	0 to 400Hz	50Hz	20	Acceleration/ deceleration reference frequency	1 to 400Hz	50Hz
© 4	Multi-speed setting (high speed)	0 to 400Hz	50Hz	21	Acceleration/ deceleration time increments	0, 1	0
© 5	Multi-speed setting (middle speed)	0 to 400Hz	30Hz	22	Stall prevention operation level	0 to 120%, 9999	110%
© 6	Multi-speed setting (low speed)	0 to 400Hz	10Hz	23	Stall prevention operation level compensation factor at double speed	0 to 150%, 9999	9999
© 7	Acceleration time	0 to 3600/360s	5s/15s *3	24 to 27	Multi-speed setting 4 speed to 7 speed	0 to 400Hz, 9999	9999
© 8	Deceleration time	0 to 3600/360s	10s/30s *3	28	Multi-speed input compensation selection	0, 1	0
© 9	Electronic thermal O/L relay	0 to 500/ 0 to 3600A *1	Rated inverter output current	29	Acceleration/ deceleration pattern selection	0, 1, 2, 3	0
10	DC injection brake operation frequency	0 to 120Hz, 9999	3Hz	30	Regenerative function selection	0, 2/0, 1, 2 *1	0
11	DC injection brake operation time	0 to 10s, 8888	0.5s	31	Frequency jump 1A	0 to 400Hz, 9999	9999
12	DC injection brake operation voltage	0 to 30%	4/2/1% *4	32	Frequency jump 1B	0 to 400Hz, 9999	9999
13	Starting frequency	0 to 60Hz	0.5Hz				
14	Load pattern selection	0, 1	1				
15	Jog frequency	0 to 400Hz	5Hz				
16	Jog acceleration/ deceleration time	0 to 3600/360s	0.5s				

\*1 The setting depends on capacities. (01160 or less 01800 or more)

\*2 The setting depends on capacities. (00023/00038 to 00083/00126, 00170/00250 to 00770/00930, 01160/01800 or more)

\*3 The setting depends on capacities. (00170 or less/00250 or more)

\*4 The setting depends on capacities. (00170 or less/00250 to 01160/01800 or more).



Parameters	Name	Setting Range	Initial Value
33	Frequency jump 2A	0 to 400Hz, 9999	9999
34	Frequency jump 2B	0 to 400Hz, 9999	9999
35	Frequency jump 3A	0 to 400Hz, 9999	9999
36	Frequency jump 3B	0 to 400Hz, 9999	9999
37	Speed display	0, 1 to 9998	0
41	Up-to-frequency sensitivity	0 to 100%	10%
42	Output frequency detection	0 to 400Hz	6Hz
43	Output frequency detection for reverse rotation	0 to 400Hz, 9999	9999
44	Second acceleration/ deceleration time	0 to 3600/360s	5s
45	Second deceleration time	0 to 3600/360s, 9999	9999
46	Second torque boost	0 to 30%, 9999	9999
47	Second V/F (base frequency)	0 to 400Hz, 9999	9999
48	Second stall prevention operation current	0.1 to 120%	110%
49	Second stall prevention operation frequency	0 to 400Hz, 9999	0Hz
50	Second output frequency detection	0 to 400Hz	30Hz
51	Second electronic thermal O/L relay	0 to 500A, 9999/ 0 to 3600A, 9999 *1	9999
52	DU/PU main display data selection	0, 5, 6, 8 to 14, 17, 20, 23 to 25, 50 to 57, 100 *2	0
54	CA terminal function selection	1 to 3, 5, 6, 8 to 14, 17, 21, 24, 50, 52, 53 *2	1
55	Frequency monitoring reference	0 to 400Hz	50Hz
56	Current monitoring reference	0 to 500A/ 0 to 3600A *1	Rated inverter output current
57	Restart coasting time	0, 0.1 to 5s, 9999/ 0, 0.1 to 30s, 9999 *1	9999
58	Restart cushion time	0 to 60s	1s
59	Remote function selection	0, 1, 2, 3	0
© 60	Energy saving control selection	0, 4, 9	0
65	Retry selection	0 to 5	0
66	Stall prevention operation reduction starting frequency	0 to 400Hz	50Hz

Parameters	Name	Setting Range	Initial Value
67	Number of retries at alarm occurrence	0, 1 to 10, 101 to 110	0
68	Retry waiting time	0 to 10s	1s
69	Retry count display erase	0	0
70	Special regenerative brake duty *3	0 to 10%	0%
71	Applied motor	0, 1, 2, 20	0
72	PWM frequency selection	0 to 15/ 0 to 6, 25 *1	2
73	Analog input selection	0 to 7, 10 to 17	1
74	Input filter time constant	0 to 8	1
75	Reset selection/ disconnected PU detection/PU stop selection	0 to 3, 14 to 17, 100 to 103, 114 to 117 *4	14
76	Alarm code output selection	0, 1, 2	0
77	Parameter write selection	0, 1, 2	0
78	Reverse rotation prevention selection	0, 1, 2	0
© 79	Operation mode selection	0, 1, 2, 3, 4, 6, 7	0
80	Motor capacity (simple magnetic flux vector control)	0.4 to 55kW, 9999/ 0 to 3600kW, 9999 *1	9999
90	Motor constant (R1)	0 to 50Ω, 9999/ 0 to 400mΩ, 9999 *1	9999
100	V/F1 (first frequency)	0 to 400Hz, 9999	9999
101	V/F1 (first frequency voltage)	0 to 1000V	0V
102	V/F2 (second frequency)	0 to 400Hz, 9999	9999
103	V/F2 (second frequency voltage)	0 to 1000V	0V
104	V/F3 (third frequency)	0 to 400Hz, 9999	9999
105	V/F3 (third frequency voltage)	0 to 1000V	0V
106	V/F4 (fourth frequency)	0 to 400Hz, 9999	9999
107	V/F4 (fourth frequency voltage)	0 to 1000V	0V
108	V/F5 (fifth frequency)	0 to 400Hz, 9999	9999
109	V/F5 (fifth frequency voltage)	0 to 1000V	0V
117	PU communication station	0 to 31	0
118	PU communication speed	48, 96, 192, 384	192

\*1 The setting depends on capacities. (01160 or less/01800 or more)

\*2 Setting of "9" can be made for the 01800 or more.

\*3 Setting can be made for the 01800 or more.

\*4 Setting of "100 to 103", "114 to 117" can be made for the 01800 or more.



Parameters	Name	Setting Range	Initial Value
119	PU communication stop bit length.	0, 1, 10, 11	1
120	PU communication parity check	0, 1, 2	2
121	Number of PU communication retries	0 to 10, 9999	1
122	PU communication check time interval	0, 0.1 to 999.8s, 9999	9999
123	PU communication waiting time setting	0 to 150ms, 9999	9999
124	PU communication CR/LF presence/absence selection	0, 1, 2	1
© 125	Terminal 2 frequency setting gain frequency	0 to 400Hz	50Hz
© 126	Terminal 4 frequency setting gain frequency	0 to 400Hz	50Hz
127	PID control automatic switchover frequency	0 to 400Hz, 9999	9999
128	PID action selection	10, 11, 20, 21, 50, 51, 60, 61	10
129	PID proportional band	0.1 to 1000%, 9999	100%
130	PID integral time	0.1 to 3600s, 9999	1s
131	PID upper limit	0 to 100%, 9999	9999
132	PID lower limit	0 to 100%, 9999	9999
133	PID action set point	0 to 100%, 9999	9999
134	PID differential time	0.01 to 10.00s, 9999	9999
135	Power-supply switchover sequence output terminal selection	0, 1	0
136	MC switchover interlock time	0 to 100s	1s
137	Waiting time at a start	0 to 100s	0.5s
138	Commercial power-supply operation switchover selection at an alarm	0, 1	0
139	Automatic switchover frequency between inverter and commercial power-supply operation	0 to 60Hz, 9999	9999
140	Backlash acceleration stopping frequency	0 to 400Hz	1Hz
141	Backlash acceleration stopping time	0 to 360s	0.5s

Parameters	Name	Setting Range	Initial Value
142	Backlash deceleration stopping frequency	0 to 400Hz	1Hz
143	Backlash deceleration stopping time	0 to 360s	0.5s
144	Speed setting switchover	0, 2, 4, 6, 8, 10, 102, 104, 106, 108, 110	4
145	PU display language selection	0 to 7	1
148	Stall prevention level at 0V input.	0 to 120%	110%
149	Stall prevention level at 10V input.	0 to 120%	120%
150	Output current detection level	0 to 120%	110%
151	Output current detection signal delay time	0 to 10s	0s
152	Zero current detection level	0 to 150%	5%
153	Zero current detection time	0 to 1s	0.5s
154	Voltage reduction selection during stall prevention operation	0, 1	1
155	RT signal reflection time selection	0, 10	0
156	Stall prevention operation selection	0 to 31, 100, 101	0
157	OL signal output timer	0 to 25s, 9999	0s
158	AM terminal function selection	1 to 3, 5, 6, 8 to 14, 17, 21, 24, 50, 52, 53 *1	1
159	Automatic switchover ON range between commercial power-supply and inverter operation	0 to 10Hz, 9999	9999
© 160	User group read selection	0, 1, 9999	9999
161	Frequency setting/key lock operation selection	0, 1, 10, 11	0
162	Automatic restart after instantaneous power failure selection	0, 1, 10, 11	0
163	First cushion time for restart	0 to 20s	0s
164	First cushion voltage for restart	0 to 100%	0%
165	Stall prevention operation level for restart	0 to 120%	110%
166	Output current detection signal retention time	0 to 10s, 9999	0.1s
167	Output current detection operation selection	0, 1	0

\*1 Setting of "9" can be made for the 01800 or more.



Parameters	Name	Setting Range	Initial Value
168	Parameter for manufacturer setting.		
169	Do not make setting.		
170	Cumulative power meter clear	0, 10, 9999	9999
171	Operation hour meter clear	0, 9999	9999
172	User group registered display/ batch clear	9999, (0 to 16)	0
173	User group registration	0 to 999, 9999	9999
174	User group clear	0 to 999, 9999	9999
178	STF terminal function selection	0 to 8, 10 to 12, 14, 16, 24, 25, 37, 60, 62, 64 to 67, 9999	60
179	STR terminal function selection	0 to 8, 10 to 12, 14, 16, 24, 25, 37, 61, 62, 64 to 67, 9999	61
180	RL terminal function selection	0 to 8, 10 to 14, 16, 24, 25, 37, 62, 64 to 67, 9999	0
181	RM terminal function selection		1
182	RH terminal function selection		2
183	RT terminal function selection		3
184	AU terminal function selection		4
185	JOG terminal function selection	0 to 8, 10 to 14, 16, 24, 25, 37, 62, 64 to 67, 9999	5
186	CS terminal function selection		6
187	MRS terminal function selection		24
188	STOP terminal function selection		25
189	RES terminal function selection		62
190	RUN terminal function selection		0
191	SU terminal function selection	0 to 5, 7, 8, 10 to 19, 25, 26, 45 to 47, 64, 70 to 78, 90 to 96, 98, 99, 100 to 105, 107, 108, 110 to 116, 125, 126, 145 to 147, 164, 170, 190 to 196, 198, 199, 9999 *1	1
192	IPF terminal function selection		2
193	OL terminal function selection		3
194	FU terminal function selection		4

Parameters	Name	Setting Range	Initial Value
195	ABC1 terminal function selection	0 to 5, 7, 8, 10 to 19, 25, 26, 45 to 47, 64, 70 to 78, 90, 91, 94 to 96, 98, 99, 100 to 105, 107, 108, 110 to 116, 125, 126, 145 to 147, 164, 170, 190, 191, 194 to 196, 198, 199, 9999 *1	99
196	ABC2 terminal function selection		9999
232 to 239	Multi-speed setting (speeds 8 to 15)	0 to 400Hz, 9999	9999
240	Soft-PWM operation selection	0, 1	1
241	Analog input display unit switchover	0, 1	0
242	Terminal 1 added compensation amount (terminal 2)	0 to 100%	100%
243	Terminal 1 added compensation amount (terminal 4)	0 to 100%	75%
244	Cooling fan operation selection	0, 1	1
245	Rated slip	0 to 50%, 9999	9999
246	Slip compensation time constant	0.01 to 10s	0.5s
247	Constant-output region slip compensation selection	0, 9999	9999
250	Stop selection	0 to 100s, 1000 to 1100s, 8888, 9999	9999
251	Output phase failure protection selection	0, 1	1
252	Override bias	0 to 200%	50%
253	Override gain	0 to 200%	150%
255	Life alarm status display	(0 to 15)	0
256	Inrush current suppression circuit life display	(0 to 100%)	100%
257	Control circuit capacitor life display	(0 to 100%)	100%
258	Main circuit capacitor life display	(0 to 100%)	100%
259	Main circuit capacitor life measuring	0, 1	0

\*1 Setting of "7, 107" can be made for the 01800 or more.

Parameters	Name	Setting Range	Initial Value
260	PWM frequency automatic switchover	0, 1	1
261	Power failure stop selection	0, 1, 2	0
262	Subtracted frequency at deceleration start	0 to 20Hz	3Hz
263	Subtraction starting frequency	0 to 120Hz, 9999	50Hz
264	Power-failure deceleration time 1	0 to 3600/ 360s	5s
265	Power-failure deceleration time 2	0 to 3600/ 360s, 9999	9999
266	Power failure deceleration time switchover frequency	0 to 400Hz	50Hz
267	Terminal 4 input selection	0, 1, 2	0
268	Monitor decimal digits selection	0, 1, 9999	9999
269	Parameter for manufacturer setting. Do not make setting.		
331	RS-485 communication station	0 to 31 (0 to 247)	0
332	RS-485 communication speed	3, 6, 12, 24, 48, 96, 192, 384	96
333	RS-485 communication stop bit length	0, 1, 10, 11	1
334	RS-485 communication parity check selection	0, 1, 2	2
335	RS-485 communication number of retries	0 to 10, 9999	1
336	RS-485 communication check time interval	0 to 999.8s, 9999	0s
337	RS-485 communication waiting time setting	0 to 150ms, 9999	9999
338	Communication operation command source	0, 1	0
339	Communication speed command source	0, 1, 2	0
340	Communication startup mode selection	0, 1, 2, 10, 12	0
341	RS-485 communication CR/LF selection	0, 1, 2	1
342	Communication EEPROM write selection	0, 1	0

Parameters	Name	Setting Range	Initial Value
343	Communication error count	—	0
495	Remote output selection	0, 1	0
496	Remote output data 1	0 to 4095	0
497	Remote output data 2	0 to 4095	0
503	Maintenance timer	0 (1 to 9998)	0
504	Maintenance timer alarm output set time	0 to 9998, 9999	9999
549	Protocol selection	0, 1	0
550	NET mode operation command source selection	0, 1, 9999	9999
551	PU mode operation command source selection	1, 2	2
555	Current average time	0.1 to 1.0s	1s
556	Data output mask time	0.0 to 20.0s	0s
557	Current average value monitor signal output reference current	0 to 500A/ 0 to 3600A *1	Rated inverter current
563	Energization time carrying-over times	(0 to 65535)	0
564	Operating time carrying-over times	(0 to 65535)	0
570	Multiple rating setting	0, 1	0
571	Holding time at a start	0.0 to 10.0s, 9999	9999
573	4mA Input check selection	1, 9999	9999
575	Output interruption detection time	0 to 3600s, 9999	1s
576	Output interruption detection level	0 to 400Hz	0Hz
577	Output interruption release level	900 to 1100%	1000%
578	Auxiliary motor operation selection	0 to 3	0
579	Motor swichover selection	0 to 3	0
580	MC switching interlock time	0 to 100s	1s
581	Start waiting time	0 to 100s	1s
582	Auxiliary motor connection-time deceleration time	0 to 3600s, 9999	1s
583	Auxiliary motor disconnection-time acceleration time	0 to 3600s, 9999	1s
584	Auxiliary motor 1 starting frequency	0 to 400Hz	50Hz
585	Auxiliary motor 2 starting frequency	0 to 400Hz	50Hz
586	Auxiliary motor 3 starting frequency	0 to 400Hz	50Hz
587	Auxiliary motor 1 stopping frequency	0 to 400Hz	0Hz

\*1 The setting depends on capacities. (01160 or less/01800 or more)



Parameters	Name	Setting Range	Initial Value
588	Auxiliary motor 2 stopping frequency	0 to 400Hz	0Hz
589	Auxiliary motor 3 stopping frequency	0 to 400Hz	0Hz
590	Auxiliary motor start detection time	0 to 3600s	5s
591	Auxiliary motor stop detection time	0 to 3600s	5s
592	Traverse function selection	0, 1, 2	0
593	Maximum amplitude amount	0 to 25%	10%
594	Amplitude compensation amount during deceleration	0 to 50%	10%
595	Amplitude compensation amount during acceleration	0 to 50%	10%
596	Amplitude acceleration time	0.1 to 3600s	5s
597	Amplitude deceleration time	0.1 to 3600s	5s
611	Acceleration time at a restart	0 to 3600s, 9999	5/15s *1
867	AM output filter	0 to 5s	0.01s
869	Current output filter	0 to 5s	0.02s
872	Input phase failure protection selection	0, 1	0
882	Regeneration avoidance operation selection	0, 1	0
883	Regeneration avoidance operation level	300 to 800V	760VDC
884	Regeneration avoidance at deceleration detection sensitivity	0 to 5	0
885	Regeneration avoidance compensation frequency limit value	0 to 10Hz, 9999	6Hz
886	Regeneration avoidance voltage gain	0 to 200%	100%
888	Free parameter 1	0 to 9999	9999
889	Free parameter 2	0 to 9999	9999
891	Cumulative power monitor digit shifted times	0 to 4, 9999	9999
892	Load factor	30 to 150%	100%
893	Energy saving monitor reference (motor capacity)	0.1 to 55kW/ 0 to 3600kW *1	LD/SLD value of applied motor capacity

Parameters	Name	Setting Range	Initial Value
894	Control selection during commercial power-supply operation	0, 1, 2, 3	0
895	Power saving rate reference value	0, 1, 9999	9999
896	Power unit cost	0 to 500, 9999	9999
897	Power saving monitor average time	0, 1 to 1000h, 9999	9999
898	Power saving cumulative monitor clear	0, 1, 10, 9999	9999
899	Operation time rate (estimated value)	0 to 100%, 9999	9999
C0 (900)	CA terminal calibration	—	—
C1 (901)	AM terminal calibration	—	—
C2 (902)	Terminal 2 frequency setting bias frequency	0 to 400Hz	0Hz
C3 (902)	Terminal 2 frequency setting bias	0 to 300%	0%
125 (903)	Terminal 2 frequency setting gain frequency	0 to 400Hz	50Hz
C4 (903)	Terminal 2 frequency setting gain	0 to 300%	100%
C5 (904)	Terminal 4 frequency setting bias frequency	0 to 400Hz	0Hz
C6 (904)	Terminal 4 frequency setting bias	0 to 300%	20%
126 (905)	Terminal 4 frequency setting gain frequency	0 to 400Hz	50Hz
C7 (905)	Terminal 4 frequency setting gain	0 to 300%	100%
C8 (930)	Current output bias signal	0 to 100%	0%
C9 (930)	Current output bias current	0 to 100%	0%
C10 (931)	Current output gain signal	0 to 100%	100%
C11 (931)	Current output gain current	0 to 100%	100%
989	Parameter copy alarm release	10/100 *1	10/100 *1
990	PU buzzer control	0, 1	1
© 991	PU contrast adjustment	0 to 63	58
Pr.CL	Parameter clear	0, 1	0
ALLC	All parameter clear	0, 1	0
Er.CL	Alarm history clear	0, 1	0
PCPY	Parameter copy	0, 1, 2, 3	0

\*1 The setting depends on capacities. (01160 or less/01800 or more)

# 6 TROUBLESHOOTING

When an alarm occurs in the inverter, the protective function is activated bringing the inverter to an alarm stop and the PU display automatically changes to any of the following error (alarm) indications.

If your fault does not correspond to any of the following errors or if you have any other problem, please contact your sales representative.

- Retention of alarm output signal.....When the magnetic contactor (MC) provided on the input side of the inverter is opened at the activation of the protective function, the inverter's control power will be lost and the alarm output will not be held.
- Alarm display .....When the protective function is activated, the operation panel display automatically switches to the above indication.
- Resetting method .....When a protective function of the inverter is activated, the power output of the inverter is blocked (motor is coasting). The inverter cannot start up again unless an automatic restart has been configured or the inverter is reset. Please observe carefully the warnings contained below in the configuration of an automatic restart or the execution of a reset.
- If protective functions were activated (i. e. the inverter switched off with an error message) follow the instructions for error correction provided in the manual for the inverter. Especially in the case of short circuits or earth contacts in the inverter output and mains overvoltages the cause of the fault must be determined prior to switching on again as a recurrence of such faults at short intervals can lead to premature aging of components or even the complete breakdown of the device. After the cause of the fault has been found and corrected the inverter can be reset and operations continue.

## 6.1 List of alarm display

Operation Panel Indication		Name
Error message	HOLD	HOLD Operation panel lock
	Er1 to Er4	Er1 to 4 Parameter write error
	rEr1 to rEr4	rEr1 to 4 Copy operation error
	Err.	Err. Error
Warnings	OL	OL Stall Prevention (overcurrent)
	oL	oL Stall prevention (overvoltage)
	rb	RB Regenerative brake prealarm
	TH	TH Electronic thermal relay function prealarm
	PS	PS PU Stop
	MT	MT Maintenance signal output
	CP	CP Parameter copy
Minor fault	Fn	FN Fan fault
Major failures	E.OC1	E.OC1 Overcurrent shut-off during acceleration
	E.OC2	E.OC2 Overcurrent cut-off during constant speed
	E.OC3	E.OC3 Overcurrent shutoff during deceleration or stop
	E.OV1	E.OV1 Regenerative overvoltage cut-off during acceleration
	E.OV2	E.OV2 Regenerative overvoltage cut-off during constant speed
	E.OV3	E.OV3 Regenerative overvoltage shut-off during deceleration or stop
	E.THT	E.THT Inverter overload shutoff (electronic thermal relay function)
	E.THM	E.THM Motor overload shutoff (electronic thermal relay function)
	E.FIn	E.FIN Fin overheat
	E.IPF	E.IPF Instantaneous power failure protection
	E.UVT	E.UVT Undervoltage protection

Operation Panel Indication		Name
E.ILF	E.ILF*	Input phase failure
E.OLT	E.OLT	Stall Prevention
E.GF	E.GF	Output side earth (ground) fault overcurrent protection
E.LF	E.LF	Output phase failure protection
E.OHT	E.OHT	External thermal relay operation '2
E.PTC	E.PTC*	PTC thermistor operation
E.OPT	E.OPT	Option alarm
E.OP1	E.OP1	Option slot alarm (e. g. communication error)
E. 1	E. 1	Option alarm (e. g. connection or contact fault)
E. PE	E. PE	Parameter storage device alarm
E.PUE	E.PUE	PU disconnection
E. RET	E. RET	Retry count excess
E. PE2	E. PE2*	Parameter storage device alarm
E. 6, E. 7, E.CPU	E. 6 / E. 7 / E.CPU	CPU error
E.CTE	E.CTE	Operation panel power supply short circuit RS-485 terminal power supply short circuit
E.P24	E.P24	24VDC power output short circuit
E.CDO	E.CDO*	Output current detection value exceeded
E.IOH	E.IOH*	Inrush resistor overheat
E.SER	E.SER*	Communication error (inverter)
E.AIE	E.AIE*	Analog input error
E. bE	E. BE	Brake transistor alarm detection/ Internal circuit error
E. 13	E.13*	Internal circuit error

\* If when employing the operating unit FR-PU04 one of the errors "E.ILF, E.PTC, E.PE2, E.CDO, E.IOH, E.SER, E.AIE, E.13" occurs, then "Fault 14" will be displayed.

---

---

# A APPENDIX

---

---

## A.1 Instructions for Compliance with the European Directives

---

### A.1.1 EMC Directive

We have self-confirmed our inverters as products compliant to the EMC Directive (second environment of conforming standard EN61800-3) and place the CE mark on the inverters.

Remarks
---------

- |   |
|---|
| <ul style="list-style-type: none"><li>• First environment<br/>Environment including residential buildings. Includes buildings directly connected without a transformer to the low voltage power supply network which supplies power to residential buildings.</li><li>• Second environment<br/>Environment including all buildings except buildings directly connected without a transformer to the low voltage power supply network which supplies power to residential buildings.</li></ul> |
|---|

### A.1.2 Notes

Install the inverter (and if necessary optional radio interference suppression filters) and perform wiring according to the following instructions.

- The inverter is equipped with a built-in EMC filter. Set the EMC filter valid (initial setting).
- Connect the inverter to an earthed power supply.
- Install a motor and a control cable written in the EMC Installation Manual (BCN-A21041-204) according to the instruction.
- The maximum cable length (shielded cable) between the frequency inverter and motor required to maintain the limiting values of the second environment is 5m when using the internal radio interference suppression filter.
- Make sure that the frequency inverter, if required (optional external) radio interference suppression filters and the motor are installed in compliance with generally recognised EMC installation regulations. It is not permitted to start up the device unless the EMC guidelines are complied with.

### A.1.3 Low Voltage Directive

We have self-confirmed our inverters as products compliant to the Low Voltage Directive (Conforming standard EN 50178) and place the CE mark on the inverters.

#### Outline of instructions

- Do not use a residual current operated protective device (RCD) as an electric shock protector without connecting the equipment to the earth. Connect the equipment to the earth securely.
- Wire the earth terminal independently. (Do not connect two or more cables to one terminal.)
- Use the cable sizes on *page 6* under the following conditions.
  - Ambient temperature: 40°C maximum
  - Wire installation: With conduits for 400V, 00380 or less  
On wall without ducts or conduits for 400V, 00470 or more  
If conditions are different from above, select appropriate wire according to EN60204 Appendix C TABLE 5.
- Use a tinned (plating should not include zinc) crimping terminal to connect the earth cable. When tightening the screw, be careful not to damage the threads.
- For use as a product compliant with the Low Voltage Directive, use PVC cable whose size is indicated on *page 6*.
- Use the moulded case circuit breaker and magnetic contactor which conform to the EN or IEC Standard.
- Use the residual current operated protective device (RCD) of type B (breaker which can detect both AC and DC). However, be aware that also AC/DC sensitive earth leakage circuit breakers can be activated when turning the main power on and off and that this behaviour can be improved through the use of AC/DC sensitive earth leakage circuit breakers with adapted triggering curve designed for the inverter. If not, provide double or reinforced insulation between the inverter and other equipment, or put a transformer between the main power supply and inverter.

- Use the inverter under the conditions of overvoltage category II (usable regardless of the earth condition of the power supply), overvoltage category III (usable with the earthed-neutral system power supply) and pollution degree 2 or lower specified in IEC664.
  - To use the inverter of 00770 or more (IP00) under the conditions of pollution degree 2, install it in the enclosure of IP 2X or higher.
  - To use the inverter under the conditions of pollution degree 3, install it in the enclosure of IP54 or higher.
  - To use the inverter of 00620 or less (IP20) outside of an enclosure in the environment of pollution degree 2, fix a fan cover with fan cover fixing screws enclosed.

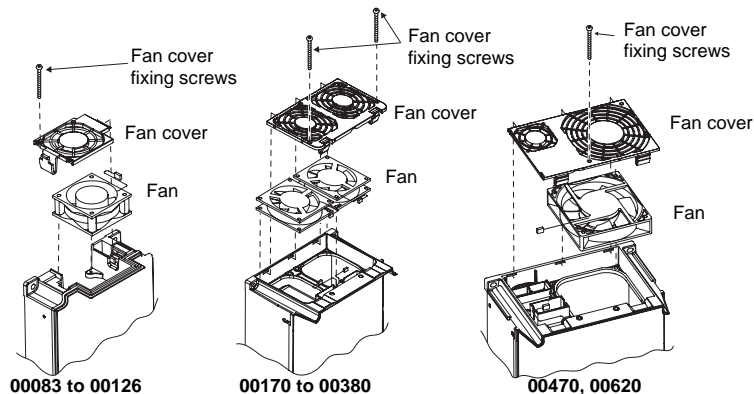

- On the input and output of the inverter, use cables of the type and size set forth in EN60204 Appendix C.
- The operating capacity of the relay outputs (terminal symbols A1, B1, C1, A2, B2, C2) should be 30VDC, 0.3A. (Relay outputs are basically isolated from the inverter internal circuit.)
- Control circuit terminals on *page 4* are safely isolated from the main circuit.

**Environment**

	During Operation	In Storage	During Transportation
Ambient temperature	-10 °C to +40/+50 °C The maximum temperature depends on the setting of the Pr. 570.	-20°C to +65°C	-20°C to +65°C
Ambient humidity	90% RH or less	90% RH or less	90% RH or less
Maximum altitude	1000m	1000m	10000m

**A.1.4 Machine directive**

The frequency inverter itself is not a machine in the spirit of the EU machine directive. The start up of the frequency inverter in a machine is prohibited so long until it has been confirmed that the entire machine complies with the provisions of Directive 89/392/EWG (machine directive).



## A.2 Instructions for UL and cUL

(Conforming standard UL 508C, CSA C22.2 No.14)

### A.2.1 Installation

This inverter is UL-listed as a product for use in an enclosure.

Design an enclosure so that the inverter ambient temperature, humidity and atmosphere satisfy the specifications. (Refer to page 1)

#### Wiring protection

For installation in the United States, branch circuit protection must be provided in accordance with the National Electrical Code and any applicable provincial codes.

For installation in Canada, branch circuit protection must be provided in accordance with the Canada Electrical Code and any applicable provincial codes.

Use the Class RK5 or Class T fuses certified by UL and cUL.

FR-F740-□□□□□-EC		00023	00038	00052	00083	00126	00170	00250	00310	00380	00470	00620	00770	00930	01160	01800	02160
Rated voltage [V]		480V or more															
Rated current [A]	Without power factor improving reactor	6	10	15	20	30	40	70	80	90	110	150	175	200	250	—	—
	With power factor improving reactor	6	10	10	15	25	35	60	70	90	100	125	150	175	200	250	300

### A.2.2 Wiring of the power supply and motor

For wiring the input (R/L1, S/L2, T/L3) and output (U, V, W) terminals of the inverter, use the UL-listed copper wires (rated at 75°C) and round crimping terminals. Crimp the crimping terminals with the crimping tool recommended by the terminal maker.

### A.2.3 Short circuit ratings

Suitable for use in a circuit capable of delivering not more than 65kA rms symmetrical amperes, 528V maximum.

### A.2.4 Motor overload protection

When using the electronic thermal relay function as motor overload protection, set the rated motor current to *Pr.9 Electronic thermal O/L relay*.

When connecting multiple motors to the inverter, install an external thermal relay individually.

## About the CD ROM

- The copyright and other rights of this enclosed CD ROM all belong to Mitsubishi Electric Corporation.
- No part of this CD ROM may be copied or reproduced without the permission of Mitsubishi Electric Corporation.
- Specifications of this CD ROM are subject to change without notice.
- We are not responsible for any damages and lost earnings, etc. from use of this CD ROM.
- Microsoft, Windows, Microsoft Windows NT are registered trademarks of Microsoft Corporation in the United States and/or other countries. Adobe and Acrobat are registered trademarks of Adobe Systems Incorporated. Pentium is a registered trademark of Intel Corporation of the United States and/or other countries. Mac OS is a registered trademark of Apple Computer, Inc., U.S.A. PowerPC is a registered trademark of International Business Machines Corporation. Other company and product names herein are the trademarks and registered trademarks of their respective owners.
- Warranty
  - We do not provide a warranty against defects in this CD ROM and related documents.
  - We are not responsible to any loss resulting from use of this product
- Acrobat Reader  
For use of Acrobat Reader contained in this CD ROM, please follow use conditions established by Adobe System Incorporated.

### ⚠ WARNING

- This is a personal computer dedicated CD ROM. Do not attempt to play it on ordinary audio devices. The loud volume may damage hearing and speakers.

## When playing the CD ROM on Windows OS

### Operating environment

The following system is required to read instruction manuals contained in this CD ROM:

Item	Specifications
OS	Microsoft Windows 95 OSR 2.0, Windows 98 Second Edition, Windows Millenium Edition, Windows NT 4.0 with Service Pack 6, Windows 2000 with Service Pack 2, Windows XP Professional or Home Edition, Windows XP Tablet PC Edition
CPU	Intel Pentium processor
Memory	64MB of RAM
Hard disk	24MB of available hard disk space
CD ROM drive	Double speed or more (more than quadruple speed is recommended)
Monitor	800x600 dot or more
Application	Acrobat Reader 4.05 or more (This CD ROM contains Acrobat Reader 5.0. Install Acrobat Reader contained in the CD ROM or download Acrobat Reader from the internet)

### Operating method of this CD ROM:

- Acrobat Reader 5.0 installation procedure
  - ① Start Windows and place this CD ROM in the CD ROM drive.
  - ② If Acrobat Reader is not installed in your computer, an installation screen of Acrobat Reader is automatically displayed.
  - ③ Install according to the instruction of installation screen of Acrobat Reader.

#### Manual installation

- ① Start Windows and place this CD ROM in the CD ROM drive.
  - ② Select a CD ROM drive (example: D drive) of "My computer" and click the right mouse button. Then, click "open" in the context menu.
  - ③ Open "WINDOWS" folder in "ACROBAT" folder in the opened folder and execute AR505ENU.EXE.
  - ④ Install according to the instruction of installation screen of Acrobat Reader.
- How to read instruction manual
    - ① Start Windows and place this CD ROM in the CD ROM drive.
    - ② "700 series documentation" PDF automatically opens.
    - ③ Click a PDF file name of the manual you want to read in the "INSTRUCTION MANUAL" list.
    - ④ PDF manual you clicked opens.

#### Manual opening of this CD ROM

- ① Start Windows and place this CD ROM in the CD ROM drive.
- ② Select a CD ROM drive (example: D drive) of "My computer" and click the right mouse button. Then, click "open" in the context menu.
- ③ Open "INDEX.PDF" in the opened folder
- ④ "700 series documentation" PDF opens. Operates according to the steps from Step ③ of "How to read instruction manual"

## When playing this CD ROM on Macintosh OS

Item	Specifications
OS	Mac OS 8.6, 9.0.4, 9.1, or Mac OS X* (* Some features may not be available.)
CPU	PowerPC processor
Memory	64MB of RAM
Hard disk	24MB of available hard disk space
CD ROM drive	Double speed or more (more than quadruple speed is recommended)
Monitor	800x600 dot or more
Application	Acrobat Reader 4.05 or more (This CD ROM contains Acrobat Reader 5.0. Install Acrobat Reader contained in the CD ROM or download Acrobat Reader from the internet)

- Operating method of this CD ROM
  - ① Start Macintosh and place this CD ROM in the CD ROM drive.
  - ② Double click on the CD ROM icon on the desk top to open the CD ROM.
  - ③ Open "MacOS" folder in "ACROBAT" folder in the opened folder and execute Acrobat Reader Installer.
  - ④ Install according to the instruction of installation screen of Acrobat Reader.
- How to read instruction manuals
  - ① Start Macintosh and place this CD ROM in the CD ROM drive.
  - ② Double click on the CD ROM icon on the desk top to open the CD ROM.
  - ③ Open "INDEX.PDF" in the opened folder
  - ④ "700 series documentation" PDF opens.
  - ⑤ Click a PDF file name of the manual you want to read in the "INSTRUCTION MANUAL" list.
  - ⑥ PDF manual you clicked opens.

HEADQUARTERS		EUROPEAN REPRESENTATIVES		EUROPEAN REPRESENTATIVES		EUROPEAN REPRESENTATIVES	
<b>MITSUBISHI ELECTRIC EUROPE B.V.</b> German Branch Gothaer Straße 8 <b>D-40880 Ratingen</b> Phone: +49 (0)2102 486-0 Fax: +49 (0)2102 486-1120 e mail: megfamail@meg.mee.com		<b>GEVA AUSTRIA</b> Wiener Straße 89 <b>AT-2500 Baden</b> Phone: +43 (0)2252 / 85 55 20 Fax: +43 (0)2252 / 488 60 e mail: office@geva.at		<b>UAB UTU POWEL LITHUANIA</b> Savanoriu Pr. 187 <b>LT-2053 Vilnius</b> Phone: +370 (0)52323-101 Fax: +370 (0)52322-980 e mail: powel@utu.lt		<b>GTS TURKEY</b> Darülaceze Cad. No. 43A KAT: 2 <b>TR-80270 Okmeydanı-Istanbul</b> Phone: +90 (0)212 / 320 1640 Fax: +90 (0)212 / 320 1649 e mail: gts@turk.net	
<b>MITSUBISHI ELECTRIC EUROPE B.V.</b> French Branch 25, Boulevard des Bouvets <b>F-92741 Nanterre Cedex</b> Phone: +33 1 55 68 55 68 Fax: +33 1 55 68 56 85 e mail: factory.automation@fra.mee.com		<b>TEHNIKON BELARUS</b> Oktjabrskaya 16/5, Ap 704 <b>BY-220030 Minsk</b> Phone: +375 (0)17 / 2104626 Fax: +375 (0)17 / 2275830 e mail: tehnikon@belsonet.net		<b>Intehsis Srl MOLDOVA</b> Cuza-Voda 36/1-81 <b>MD-2061 Chisinau</b> Phone: +373 (0)2 / 562 263 Fax: +373 (0)2 / 562 263 e mail: intehsis@mdl.net		<b>CSC Automation UKRAINE</b> 15, M. Raskova St., Fl. 10, Off. 1010 <b>UA-02002 Kiev</b> Phone: +380 (0)44 / 238 83 16 Fax: +380 (0)44 / 238 83 17 e mail: csc-a@csc-a.kiev.ua	
<b>MITSUBISHI ELECTRIC EUROPE B.V.</b> Irish Branch Westgate Business Park, Ballymount <b>IRL-Dublin 24</b> Phone: +353 (0) 1 / 419 88 00 Fax: +353 (0) 1 / 419 88 90 e mail: sales.info@meir.mee.com		<b>Getronics b.v. BELGIUM</b> Control Systems Pontbeeklaan 43 <b>BE-1731 Asse-Zellik</b> Phone: +32 (0)2 / 467 17 51 Fax: +32 (0)2 / 467 17 45 e mail: infoautomation@getronics.com		<b>Getronics b.v. NETHERLANDS</b> Control Systems Donauweg 2 B <b>NL-1043 AJ Amsterdam</b> Phone: +31 (0)20 / 587 6700 Fax: +31 (0)20 / 587 6839 e mail: info.gia@getronics.com		<b>CONSYS RUSSIA</b> Promyshlennaya St. 42 <b>RU-198099 St Petersburg</b> Phone: +7 812 / 325 36 53 Fax: +7 812 / 325 36 53 e mail: consys@consys.spb.ru	
<b>MITSUBISHI ELECTRIC EUROPE B.V.</b> Italian Branch Via Paracelso 12 <b>I-20041 Agrate Brianza (MI)</b> Phone: +39 039 60 53 1 Fax: +39 039 60 53 312 e mail: factory.automation@it.mee.com		<b>TELECON CO. BULGARIA</b> 4, A. Ljapchev Blvd. <b>BG-1756 Sofia</b> Phone: +359 (0)2 / 97 44 058 Fax: +359 (0)2 / 97 44 061 e mail: —		<b>Motion Control NETHERLANDS</b> Automation b.v. Markenweg 5 <b>NL-7051 HS Varsseveld</b> Phone: +31 (0)315 / 257 260 Fax: +31 (0)315 / 257 269 e mail: —		<b>ELEKTROSTYLE RUSSIA</b> ul. Garschina 11 <b>RU-140070 Moscow Oblast</b> Phone: +7 095 / 557 9756 Fax: +7 095 / 746 8880 e mail: mjuly@elektrostyle.ru	
<b>MITSUBISHI ELECTRIC EUROPE B.V.</b> Spanish Branch Carretera de Rubí 76-80 <b>E-08190 Sant Cugat del Vallés</b> Phone: +34 9 3 565 3131 Fax: +34 9 3 589 2948 e mail: industrial@sp.mee.com		<b>INEA CR d.o.o. CROATIA</b> Drvinje 63 <b>HR-10000 Zagreb</b> Phone: +385 (0)1 / 3667140 Fax: +385 (0)1 / 3667140 e mail: —		<b>Beijer Electronics AS NORWAY</b> Teglværksveien 1 <b>NO-3002 Drammen</b> Phone: +47 (0)32 / 24 30 00 Fax: +47 (0)32 / 84 85 77 e mail: info@beijer.no		<b>ELEKTROSTYLE RUSSIA</b> Krasnij Prospekt 220-1, Office 312 <b>RU-630049 Novosibirsk</b> Phone: +7 3832 / 10 66 18 Fax: +7 3832 / 10 66 26 e mail: elo@elektrostyle.ru	
<b>MITSUBISHI ELECTRIC CORPORATION</b> Office Tower "Z" 14 F 8-12,1 chome, Harumi Chuo-Ku <b>Tokyo 104-6212</b> Phone: +81 3 622 160 60 Fax: +81 3 622 160 75		<b>AutoCont CZECH REPUBLIC</b> Control Systems s.r.o. Nemocnicni 12 <b>CZ-70200 Ostrava 2</b> Phone: +420 59 / 6152 111 Fax: +420 59 / 6152 562 e mail: consys@autocont.cz		<b>MPL Technology Sp. z o.o. POLAND</b> ul. Sliczna 36 <b>PL-31-444 Kraków</b> Phone: +48 (0)12 / 632 28 85 Fax: +48 (0)12 / 632 47 82 e mail: krakow@mpl.pl		<b>ICOS RUSSIA</b> Ryazanskij Prospekt, 8A, Office 100 <b>RU-109428 Moscow</b> Phone: +7 095 / 232 0207 Fax: +7 095 / 232 0327 e mail: mail@icos.ru	
<b>MITSUBISHI ELECTRIC EUROPE B.V.</b> UK Branch Travellers Lane <b>GB-Hatfield Herts. AL10 8 XB</b> Phone: +44 (0) 1707 / 27 61 00 Fax: +44 (0) 1707 / 27 86 95 e mail: automation@meuk.mee.com		<b>louis poulsen DENMARK</b> industri & automation Geminivej 32 <b>DK-2670 Greve</b> Phone: +45 (0)43 / 95 95 95 Fax: +45 (0)43 / 95 95 91 e mail: lpia@lpmail.com		<b>Sirius Trading &amp; Services srl ROMANIA</b> Str. Biharia Nr. 67-77 <b>RO-013981 Bucuresti 1</b> Phone: +40 (0) 21 / 201 1146 Fax: +40 (0) 21 / 201 1148 e mail: sirius@siriustrading.ro		<b>SMENA RUSSIA</b> Polzunova 7 <b>RU-630051 Novosibirsk</b> Phone: +7 095 / 416 4321 Fax: +7 095 / 416 4321 e mail: smena-nsk@yandex.ru	
<b>MITSUBISHI ELECTRIC EUROPE B.V.</b> USA 500 Corporate Woods Parkway <b>Vernon Hills, IL 60061</b> Phone: +1 847 478 21 00 Fax: +1 847 478 22 83		<b>UTU Elektrotehnika AS ESTONIA</b> Pärnu mnt.160i <b>EE-10621 Tallinn</b> Phone: +372 (0)6 / 51 72 80 Fax: +372 (0)6 / 51 72 88 e mail: utu@utu.ee		<b>ACP Autocomp a.s. SLOVAKIA</b> Chalupkova 7 <b>SK-81109 Bratislava</b> Phone: +421 (02)5292-2254 Fax: +421 (02)5292-2248 e mail: info@acp-autocomp.sk		<b>SSMP Rosgidromontazh Ltd RUSSIA</b> 23, Lesoparkovaya Str. <b>RU-344041 Rostov On Don</b> Phone: +7 8632 / 36 00 22 Fax: +7 8632 / 36 00 26 e mail: —	
<b>MITSUBISHI ELECTRIC AUTOMATION</b> 500 Corporate Woods Parkway <b>Vernon Hills, IL 60061</b> Phone: +1 847 478 21 00 Fax: +1 847 478 22 83		<b>UTU POWEL OY FINLAND</b> Box 236 <b>FIN-28101 Pori</b> Phone: +358 (0)2 / 550 800 Fax: +358 (0)2 / 550 8841 e mail: tehoelektroniikka@urhotuominen.fi		<b>INEA d.o.o. SLOVENIA</b> Stegne 11 <b>SI-1000 Ljubljana</b> Phone: +386 (0)1 513 8100 Fax: +386 (0)1 513 8170 e mail: inea@inea.si		<b>STC Drive Technique RUSSIA</b> Poslannikov per., 9, str.1 <b>RU-107005 Moscow</b> Phone: +7 095 / 786 21 00 Fax: +7 095 / 786 21 01 e mail: info@privod.ru	
<b>MITSUBISHI ELECTRIC AUTOMATION</b> 500 Corporate Woods Parkway <b>Vernon Hills, IL 60061</b> Phone: +1 847 478 21 00 Fax: +1 847 478 22 83		<b>UTEKO A.B.E.E. GREECE</b> 5, Mavrogenous Str. <b>GR-18542 Piraeus</b> Phone: +302 (0)10 / 42 10 050 Fax: +302 (0)10 / 42 12 033 e mail: uteco@uteco.gr		<b>Beijer Electronics AB SWEDEN</b> Box 426 <b>S-20124 Malmö</b> Phone: +46 (0)40 / 35 86 00 Fax: +46 (0)40 / 35 86 02 e mail: info@beijer.de		<b>SHERF Motion Techn. Ltd ISRAEL</b> Rehov Hamerkava 19 <b>IL-58851 Holon</b> Phone: +972 (0)3 / 559 54 62 Fax: +972 (0)3 / 556 01 82 e mail: —	
<b>MITSUBISHI ELECTRIC AUTOMATION</b> 500 Corporate Woods Parkway <b>Vernon Hills, IL 60061</b> Phone: +1 847 478 21 00 Fax: +1 847 478 22 83		<b>Meltrade Automatika Kft. HUNGARY</b> 55, Harmat St. <b>HU-1105 Budapest</b> Phone: +36 (0)1 / 2605 602 Fax: +36 (0)1 / 2605 602 e mail: office@meltrade.hu		<b>ECONOTEC AG SWITZERLAND</b> Postfach 282 <b>CH-8309 Nürensdorf</b> Phone: +41 (0)1 / 838 48 11 Fax: +41 (0)1 / 838 48 12		<b>AFRICAN REPRESENTATIVE</b> <b>CBI Ltd SOUTH AFRICA</b> Private Bag 2016 <b>ZA-1600 Isando</b> Phone: +27 (0)11 / 928 2000 Fax: +27 (0)11 / 392 2354 e mail: cbi@cbi.co.za	
<b>MITSUBISHI ELECTRIC EUROPE B.V.</b> Latvian Branch Lienes iela 28 <b>LV-1009 Riga</b> Phone: +371 784 2280 Fax: +371 784 2281 e mail: utu@utu.lv		<b>SIA POWEL LATVIA</b> Lienes iela 28 <b>LV-1009 Riga</b> Phone: +371 784 2280 Fax: +371 784 2281 e mail: utu@utu.lv		<b>Beijer Electronics AB SWEDEN</b> Box 426 <b>S-20124 Malmö</b> Phone: +46 (0)40 / 35 86 00 Fax: +46 (0)40 / 35 86 02 e mail: info@beijer.de		<b>AFRICAN REPRESENTATIVE</b> <b>CBI Ltd SOUTH AFRICA</b> Private Bag 2016 <b>ZA-1600 Isando</b> Phone: +27 (0)11 / 928 2000 Fax: +27 (0)11 / 392 2354 e mail: cbi@cbi.co.za	

# **MITSUBISHI ELECTRIC CORPORATION**

Gothaer Straße 8	Phone: +49 2102 486-0	Fax: +49 2102 486-7170	www.mitsubishi-automation.de
D-408 80 Ratingen	Hotline: +49 1805 000-765	megfa-mail@meg.mee.com	www.mitsubishi-automation.com